



Advanced Yard Design Optimiser

Prepared by: Mark Biddle
Version: 0.1
Status: 1st draft.
Date: 1st Feb 2010

Contents

1. Introduction	3
1.1. Purpose of this Document	3
1.2. Scope of Document	3
2. Overview.....	3
3. Installation and Hardware Requirements	3
4. How to Design a Yard.....	4
4.1. Capture a scale diagram of your site	4
4.2. Import Scale Diagram into Advanced Yard Designer	5
4.3. Zooming and Navigation	5
4.4. Define New Shapes and fill with Parking Slots.....	6
4.5. Using Complex Shapes	7
4.6. Shape Transformations.....	8
4.7. Other Shapes and Logos	9
4.8. Define Roads.....	10
4.9. Define Container Attachments	11
4.10. Test Roads.....	11
4.11. User Tips	12

1. Introduction

1.1. Purpose of this Document

This document is designed to provide a business summary of Vehnet Advanced Yard Design Optimiser. It is designed to give an overview of this new product.

1.2. Scope of Document

The document is intended to be a general overview and is not customer specific. Each customer should contact Vehnet for individual advice or specification and quote.

2. Overview

AYDO enables users to identify and accurately 'draw around' the perimeter of the site, the buildings, major features and roadways. These co-ordinates are then imported into your personal copy of AYDO and appear as a to-scale individual canvas, allowing individual yards to be designed, using clever, but easy to use tools.

Most effective use of the Yard

AYDO can count the number of parking spaces in any area, but using the Complex Shape Template facility, it is possible to auto-fill the area with right-sized parking slots and count them up. A true-scale tool from the desktop or laptop allows drag-and-drop of different parking options and assesses their impact.

AYDO enables users to see all these options at a glance and share them with colleagues, before making the changes in the physical yard.

In addition, the Roadways functionality will allow users to calculate the fastest route from one parking or location to another.

Potential hazards identified and security increased

A virtual representation of the yard helps potential hazards to be quickly identified, these might be converging traffic flows, sharp or blind corners, poorly lit areas or other factors which could compromise the safety of your site. AYDO allows users to view the yard from a 'bird's eye perspective. Using AYDO, traffic sign icons may be added to indicate hazards, then as users click the signs, they can be hyperlinked to related safety notes.

Create high quality drawings of yard capacities and capabilities

Background watermarks of your company logo and other images can be added to the drawing, and professional icons of people, trucks, cars, trains and ships can also be dropped in. Buildings and facilities can be labelled from a range of available fonts and colour can be used to emphasize special features. The final version can be easily exported to a jpeg format for easy publication, either on the web, as part of a presentation or in business reports.

See the [User Tips](#) section below to help you get started.

3. Installation and Hardware Requirements

AYDO is a self extracting application which can be downloaded from the following website, <http://www.vehnet.co.uk/page66/Free-Advanced-Yard-Designer-And-Optimiser>

The application needs a minimum of 2Gb of memory and 1Gb of disk space.

It runs on all Microsoft Operating System platforms.

For lower specification PCs, please untick the **Window / Preferences / High Quality Graphics Mode** tick box.

4. How to Design a Yard

4.1. Capture a scale diagram of your site

Using AYDO / Drawing Tools it is possible to quickly insert various formatted shapes, where each shape can represent an area, a Parking Slot or building etc, but a more efficient initial step is to use the Google Maps based **DrawBoundary** tool to map out your site perimeter and large buildings etc.

The DrawBoundary tool can be via the following URL,
<http://tracks.vehnet.co.uk/tools/drawboundary.aspx>

Boundary Drawing Tool

- 1: Please enter your address and then click Find:
- 2: Zoom and drag the map until the entire site you wish to draw around is in the view.
- 3: Click the start button below the map to enable drawing and then click points around the perimeter of the site.



Follow steps 1 to 3 above then having clicked the corner points on your site perimeter, if you wish to also draw other large Zones, such as buildings, click the *Start* button again and mark out its perimeter as well. Click *Finish As Zone* then *Export* to create an XML file representation of your site. Now Save the XML file to a folder on your PC.

4.2. Import Scale Diagram into Advanced Yard Designer

Open the YardDesigner application which you have previously downloaded then click **File / open From XML** and navigate to the XML file which you have just saved, now highlight it and Click **Open**. (Note, it is also possible to import into AYDO from a DXF file),

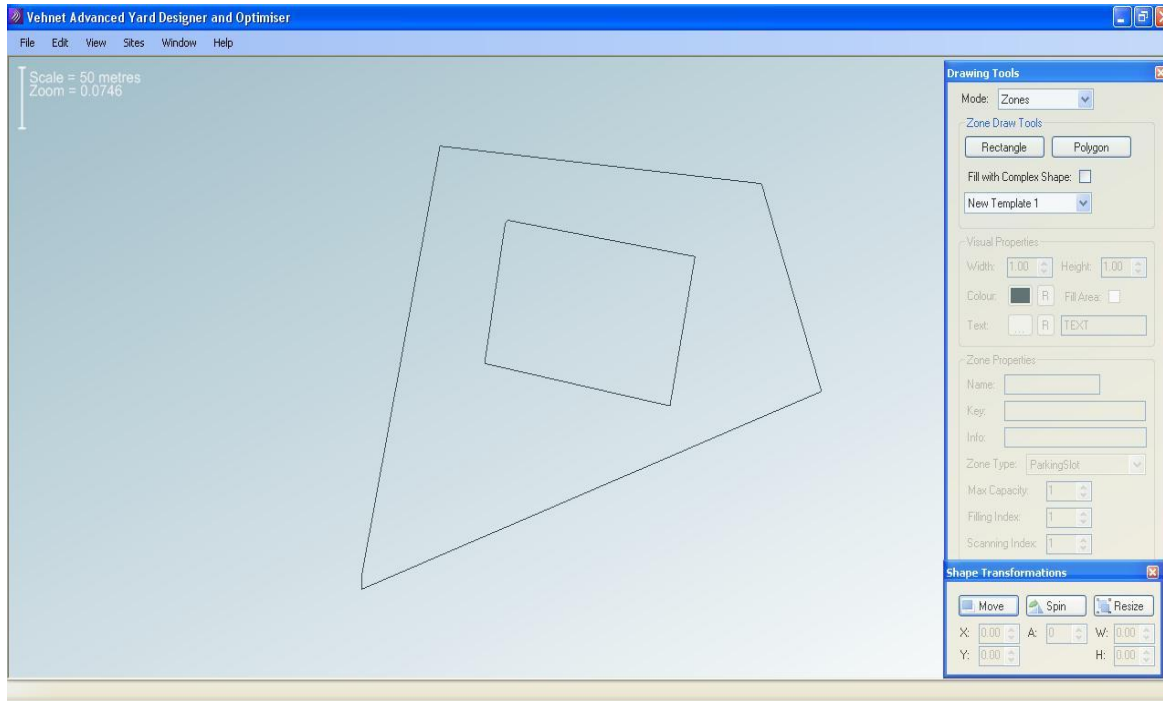

You now have a true scale diagram of your site to which you can add individual parking slots and buildings, logos etc.

4.3. Zooming and Navigation

The simplest way to zoom and navigate around the design window is via **Window / Camera Controls**,



If you have a mouse wheel, it is quicker to zoom in and out by rolling the wheel. To navigate around more quickly, hover on 1 of the borders of the design window until a large blue arrow appears then click the left mouse button. You can also zoom into just the selected object (ie Zone or Shape) by **View / Zoom to Selection**. With no object selected, this will zoom to display your whole site.

Notes –

1. To “Toggle Off” the current function being used in the design window, use **Escape** or **right mouse click**. Depending on the function being used, occasionally you have to press **Escape** **right mouse click** twice.
2. You can save your yard diagram as an XML file using **File / Save to XML**.
3. You can also save your yard diagram as a JPEG file using **File / Save Image**.

4.4. Define New Shapes and fill with Parking Slots

Now use **Window / Drawing Tools** to insert regular or irregular shapes inside your perimeter:-

- Press Escape the *Rectangle* or *Polygon* button.
- For rectangles, define its Width, Height and Colour.
- Change the *Zone Type* of your shape to "Container"
- Click in the Design window where you wish the shape to appear.
- Escape to "toggle off" the rectangle / polygon insert method.

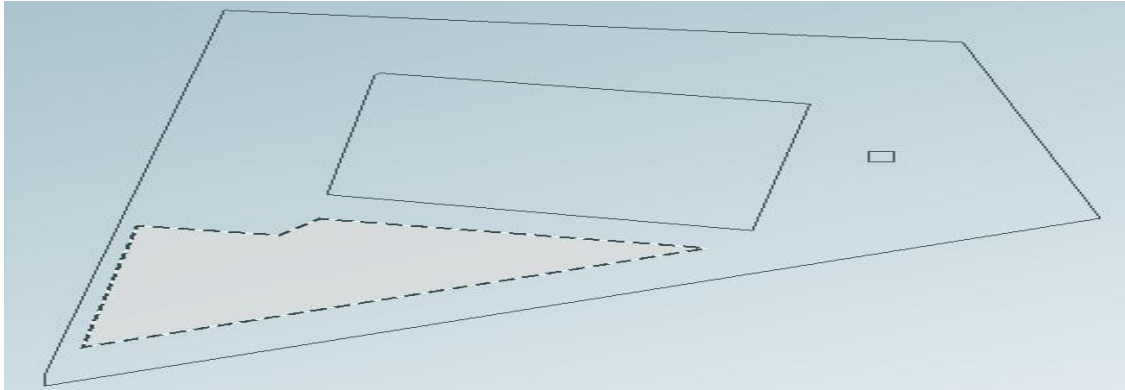

- The selected shape can now be automatically filled with Parking Slots using the **Complex Shape** functionality.

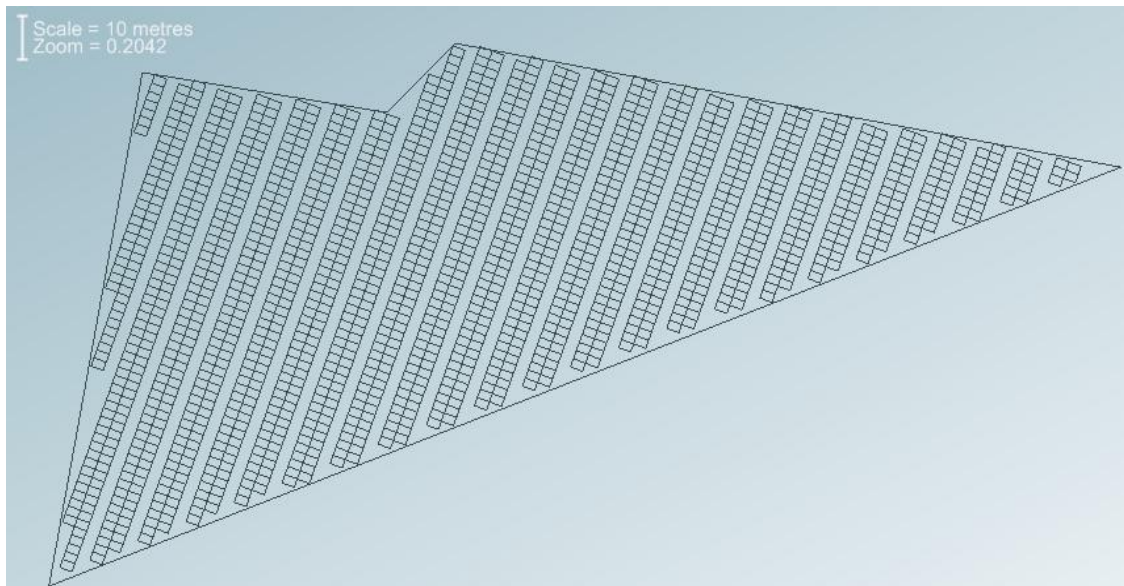

4.5. Using Complex Shapes

This option allows you to automatically fill your "Container" shape with "Parking Slots" (see image above). Select **Window / Complex Shape Templates** to create your own user defined template for filling a "Container" with "Parking Slots". Typically, each Parking Slot has the capacity for 1 vehicle.

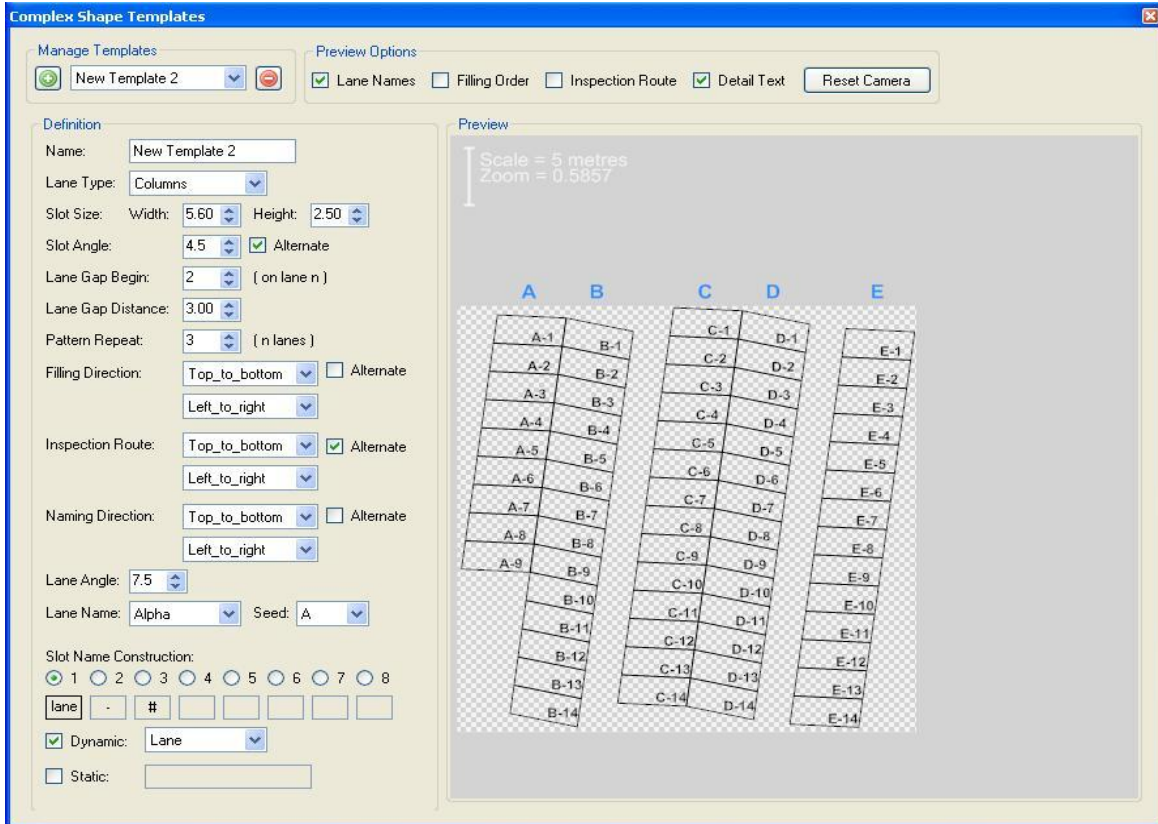

Use the **Definition** fields to define the characteristics of "Parking Slots" to be created by this template. Each definition change you make is reflected in the **Preview** window on the right hand side. For example, the *Width*, *Height*, *Angle* and orientation (*Lane Type*) can be changed according to your requirements.

The driving lane or road characteristics are defined in the *Lane Gap* fields.

Filling Direction, *Inspection Route* fields and *Filling Order* plus *Inspection Route* tick boxes define and display the anticipated sequence in which "Parking Slots" are filled / inspected.

Each individual "Parking Slot" can be automatically assigned its own identifying name in several possible directions using the *Name Direction*, *Lane Name* and *SlotName Construction* fields and *Lane Names* plus *Detail Text* tick boxes.

Having defined a template, you can create additional templates by clicking on the green plus icon or you can save your template(s) by simply closing the **Complex Shape Templates** window.

Your template is now available for use in filling a "Container" with "Parking Slots":- (see 2nd image in the section [Define New Shapes](#) section)

- Select the "Container" you wish to fill.
- In Drawing Tools, click the *Fill with Complex Shape* button.

4.6. Shape Transformations

Having inserted an object (ie "Container" Zone, "ParkingSlot" Zone, Image or Shape), you may wish to *Move*, *Spin* (rotate) or *Resize* it.

All of these can be actioned using **Window / Shape Transformations**.

Suppose you wish to insert a single row of "Parking Slots" under the top perimeter of your site,

- Click the *Rectangle* button.
- Set *Zone Type* to "Container" and tick *Fill with Complex Shape* (select your template from drop down list).
- Enter your required *Width* and *Height* (and optionally *Colour*).
- Click in the design window to insert your shape.
- Using the left mouse click, lasso your shape so a dashed border appears around it.
- Now click the *Spin* button to rotate the shape then press Escape to "toggle off" the Spin method.
- Click *Move* to move it.

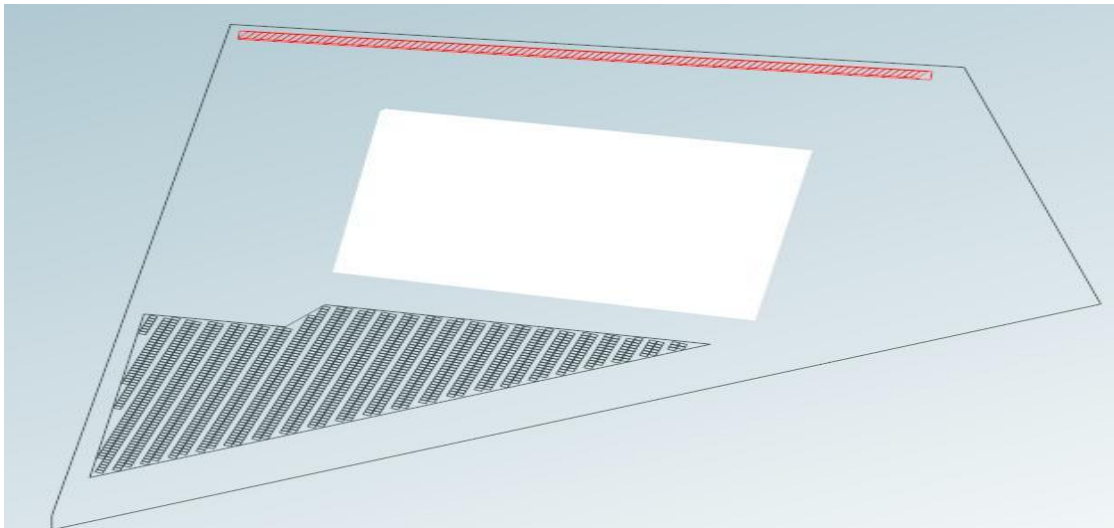

4.7. Other Shapes and Logos

Once you have inserted all your "Parking Slots" and orientated them correctly, you can insert user defined *Text*, *Lines* and *Ellipses* by using **Drawing Tools** and changing *Mode* to "Shapes". Once again, there is the option to define your own *Width*, *Height* and *Colour* etc.

For *Text* entries, type your required text into the **Drawing Tools / Visual Properties** textbox. If your text does not appear, untick the **Window / Preferences – Hide Text Shape..** box.

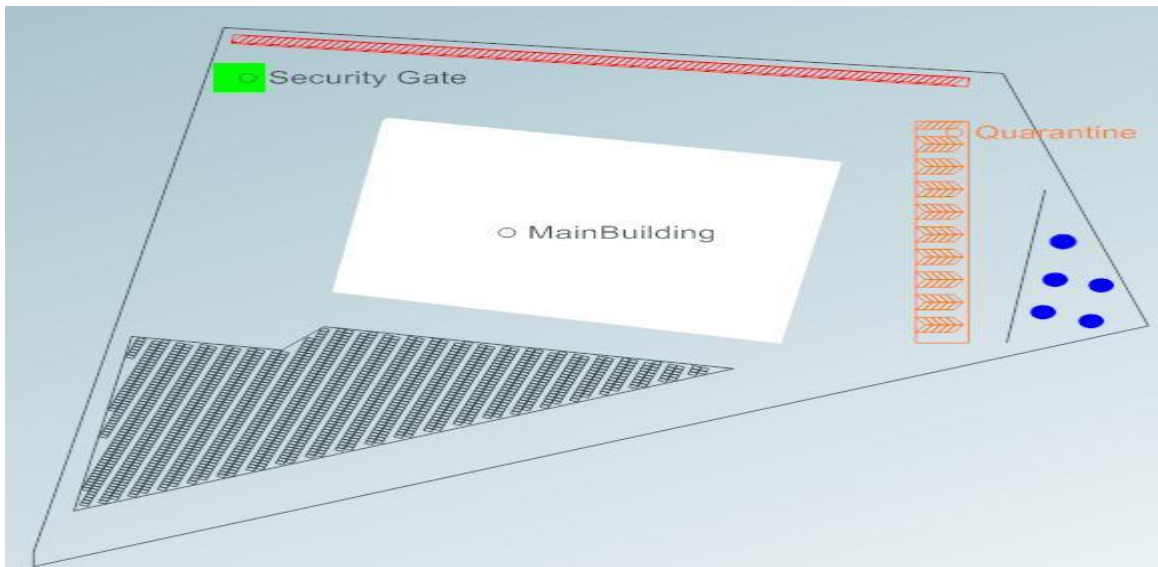

Standard Cut, Copy, Paste and Delete functionality is also available, so it is possible to manipulate and re use the whole or part of any Zone or Shape that you have already created.

Images (such as company logos) can be inserted using **Window / Custom Icons**. Locate your image, change the *Default Width* and *Height* values accordingly, then drag and drop it onto the desired position. Once your logo has been imported, it can still be resized in the same way as other shapes (see earlier section).

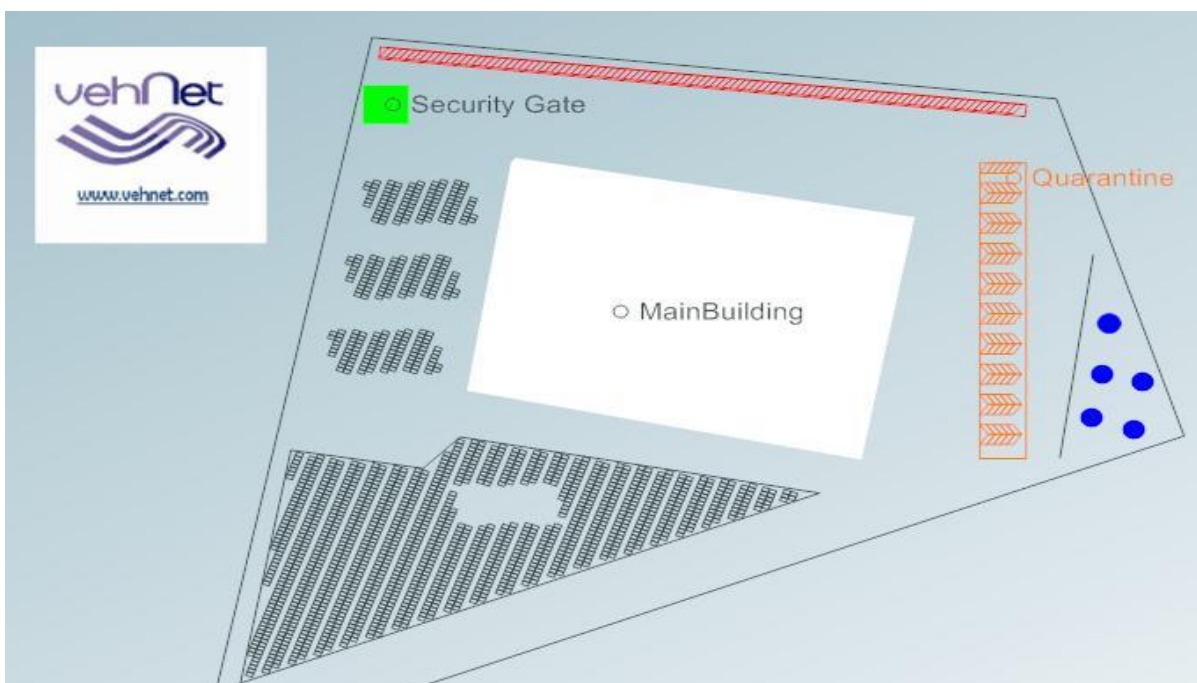

4.8. Define Roads

In order to link your "Containers" together and subsequently determine the shortest route and actual distance between any two points within your site, you need to draw your inter-connecting roads.

Within **Drawing Tools**, change the *Mode* to "Roads", optionally select a *Road Type* (default is DualWay), then click the *Draw Road* button.

In the design window, click on the starting position of your proposed road, hold down the left mouse button and drag to the first junction point on your road, then release the mouse. To connect another road to the first road, click in the circular node on either end of your first road and again hold down the left mouse button and drag to the next junction point on your road.

You can also create a new road which is unconnected to your original road and then eventually connect it to your original road. This is achieved by releasing the new road's end node on top of an existing node.

Two roads are considered joined / connected if the arrow heads on their end points are within the same node.

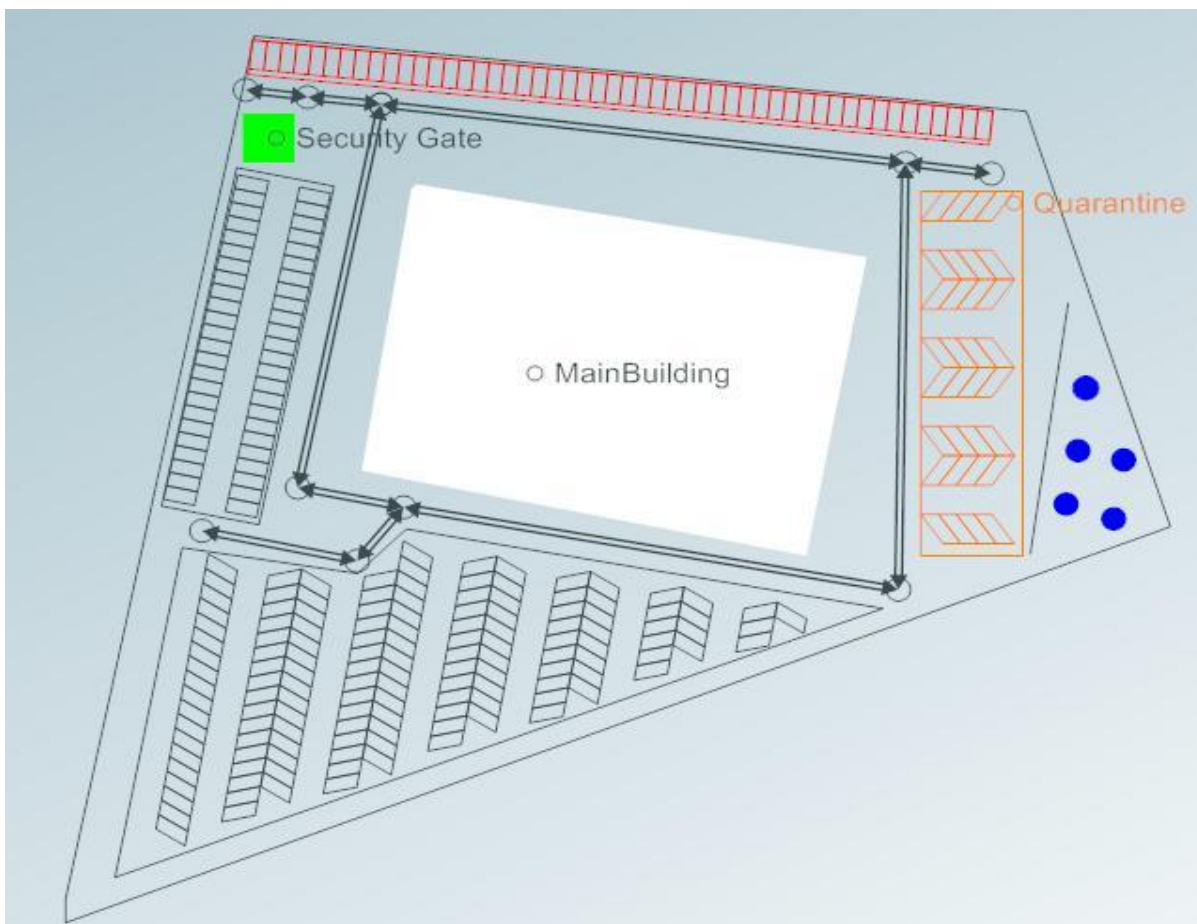

Splitting Roads – If you want to break up an existing road into smaller sections you can split it by highlighting your road and then clicking the **Split Road** button (ensure selected *Mode* is "Roads"). This will split your road in half.

Moving Roads – Roads can only be moved by first selecting one of its nodes then choosing the **Move** function. Moving a node will also move / stretch all the roads attached to it.

4.9. Define Container Attachments

In order to determine the shortest route and actual distance between any two points within your site, your road nodes must be attached to at least one "Container". Road nodes can only be attached to Zones whose *Zone Type* is "Container".

You can improve the accuracy of the route finding and distance calculations, by optionally drawing roads within your "Containers" (filled with "ParkingSlots") to represent the minor roads between your "ParkingSlots".

To attach a node to a "Container", select the node and move it onto the edge (or within) of the required "Container". Click on the Container Attachment button in **Drawing Tools / Roads**.

A node is considered as connected to a "Container" if the arrow heads of a node are displayed within a box.

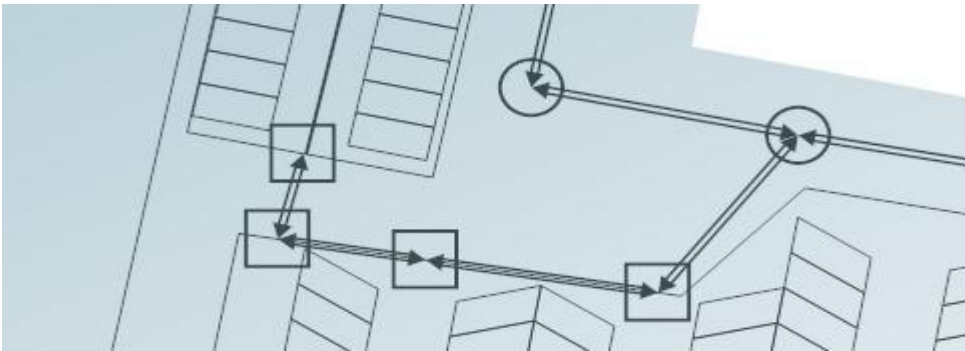

4.10. Test Roads

The Road Test functionality can be found in **Drawing Tools / Roads / Test Roads**.

Road Test *Start* and *End Points* must be either nodes, "Containers", Shapes or "ParkingSlots". Test *Start* and *End Points* can't be on any part of a road which is not a node.

To begin, click the *Enable Test Mode* tick box then do :-

- Click the *Start Point* button then, on the design window, select where you want the *Start Point* to be.
- Click the *End Point* button then, on the design window, select where you want the *End Point* to be.
- Click the *Calculate Shortest Path* button – the shortest path will now be displayed.

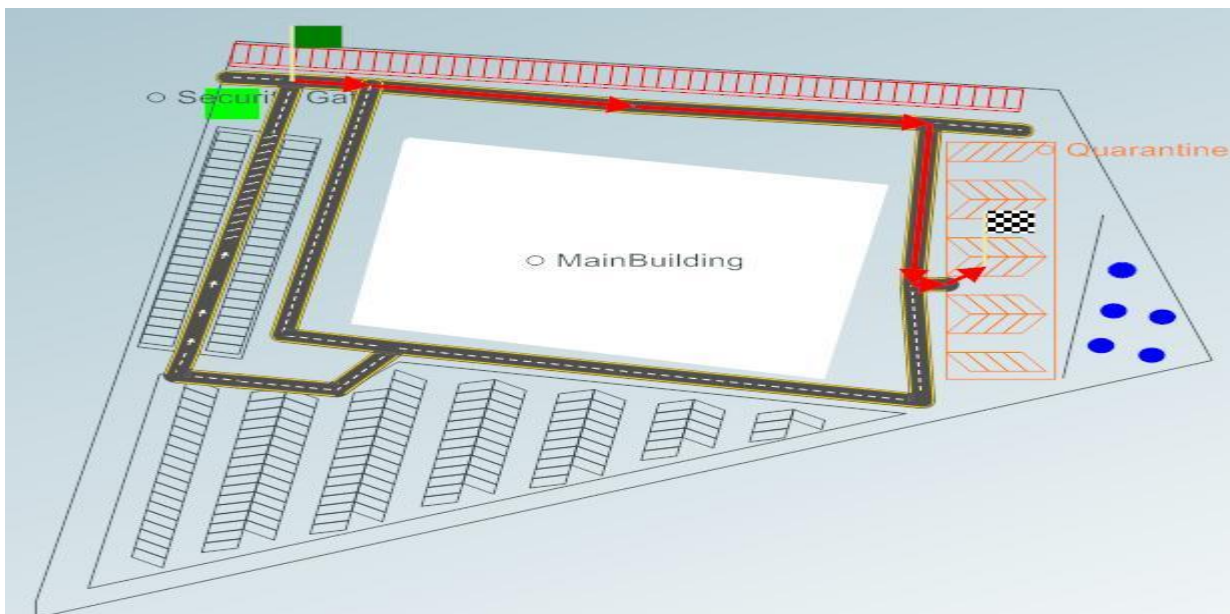

Before beginning **Test Roads**, you may need to do **Edit / Zoom to Selection** – this will display your whole site. (ensure no objects are selected before hand).

If you can't see your *Start Point* and *End Point* on the same screen and don't wish to zoom to see your whole site, You have the option to tick the *Show Car Animation*, and *Camera Follow* buttons.

Once you have run *Test Mode*, the calculated distance is displayed at the bottom of the **Drawing Tools** window. When you have finished using **Test Roads**, remember to untick the *Enable Test mode* box.

4.11. User Tips

- To “Toggle Off” the current option / function being used in the design window, press Escape. Depending on the function currently being used, occasionally you will have to press Escape or right mouse click twice.
- As you add more detail to your diagram, you can save it under a new filename as an XML file using **File / Save to XML**, then re-import later using **File / Open from XML**.
- Lasso your object or collection objects using the left mouse click, then drag around the objects. Alternatively you can select a random set of objects by first holding down the Control key.
- If AYDO is running too slowly, untick the **Preferences / High Quality Graphics Mode** tick box.
- If any of the function Windows disappear, use Window / Reset Window Locations to re-display them.
- For faster editing of your site diagram, use Control+Q, Control+W and Control+E for **Move**, **Spin** and **Resize** respectively.
- **Selecting zones within a container zone:**
If you have a container zone selected, and you hit Control+A, all of its child zones are also selected automatically. This avoids the problem of lassoing wrong shapes with the mouse.
- **What does the function View / Grid Legend do?**
The Grid Legend occupies the top-right hand corner of the screen, opposite to the Scale Legend which takes up the top left-hand corner. You may not have seen it because by default the Draw Tools window is fixed to the top right so it is probably obscuring it from view. The Grid Legend gives you a preview of what your chosen grid dimensions look like in the current zoom level.
- The AYDO Configuration files are held in:-
C:\Documents and Settings\{User}\Local Settings\Application Data (for Windows XP).